



OPTIGO - READY-STEADY-GO



Optigo OP5 Manual

©Copyright AB Regin, Sweden, 2010

READY STEADY GO



THE CHALLENGER IN BUILDING AUTOMATION

DISCLAIMER

The information in this manual has been carefully checked and is believed to be correct. Regin however, makes no warranties as regards the contents of this manual and users are requested to report errors, discrepancies or ambiguities to Regin, so that corrections may be made in future editions. The information in this document is subject to change without prior notification.

The software described in this document is supplied under license by Regin and may be used or copied only in accordance with the terms of the license. No part of this document may be reproduced or transmitted in any form, in any fashion, electronically or mechanically, without the express, written permission of Regin.

COPYRIGHT

© AB Regin. All rights reserved.

TRADEMARKS

Optigo is a registered trademark of AB Regin.

Some product names mentioned in this document are used for identification purposes only and may be the registered trademarks of their respective companies.

August 2010

Document revision: 2010-08-26

Table of contents

Chapter 1 About this manual	5
More information	5
Chapter 2 Introduction to Optigo	6
Optigo controllers	6
Optigo OP5	7
Chapter 3 Technical data	8
Chapter 4 Installation and wiring	10
Installation	10
Wiring	10
Supply voltage	10
Inputs and outputs	11
Chapter 5 Control modes	12
Control mode 1, Temperature control	13
Control mode 2, CO ₂ control	15
Control mode 3, Humidity control	16
Control mode 4, Pressure control	17
Control mode 5, Pressure control with outdoor temperature compensation of the pressure setpoint.	18
Chapter 6 Display and encoder	19
The Basic level	19
The 10-second level	20
Display symbols	20
Chapter 7 Setpoint	21
Chapter 8 Configuration	22
Menus 1.0 – 5.0	22
Menu X.1 Output signals (Control mode 1)	22
Transmitter range (Control modes 2, 3, 4 and 5)	22
Menus X.2 Neutral zone (Control mode 1 and 3)	23
Menus X.3 P-band	24
Menus X.4 I-time	24
Menu 1.5 Damper minimum position (Control mode 1 only)	24
Menu 5.9 Start point for outdoor compensation (Control mode 5 only)	24
Menu 5.9 Maximum compensation (Control mode 5 only)	25
Menus X.11 I/O	25
Menu OK	25
Storage of settings	26

Reset to factory setting

26

Chapter 9 **Index**

27

Chapter 1 About this manual

This manual describes the controller Optigo 5. It is applicable to program revisions from R18.

More information

More information on OP5 can be found in:

- *Optigo controllers* – Sales brochure for Optigo controllers
- *Optigo product instruction*

The information can be downloaded from the Regin website, www.regin.se.

Chapter 2 Introduction to Optigo

Optigo controllers

Optigo is a range of pre-programmed, configurable controllers that can be set to handle everything from temperature control or humidity control to CO₂ control or pressure control. The controller is intended to be used in residential, commercial and light-industrial locations.

OP 5 and OP 10

The Optigo series comprises two different types, OP5 and OP10.

OP5 has 5 inputs/outputs and can be configured to control Temperature, CO₂, Humidity or Pressure. From revision 18, there is a new analogue input for connection of an external PT1000 setpoint device for control mode 1 (Temperature control).

OP10 has 10 inputs/outputs and can be configured to control Temperature (ventilation control with heating and cooling), Waterheated radiator-heating with outdoor temperature dependent control-curve or Domestic hot water control. From revision 20, there is a new analogue input for connection of an external PT1000 setpoint device for control modes 1-4. OP10 also has a week-based scheduler. OP 10 is available in two versions, OP 10 with 24 V AC supply voltage and OP 10-230 with 230 V AC supply voltage. For more information, please refer to the separate Optigo OP10 manual.

Mounting

Optigo is designed primarily for DIN-rail mounting but can also be screw-mounted to any suitable surface. The controller is intended for stationary indoor use.



Optigo OP5

Optigo OP5 is a pre-programmed, configurable controller. It has been designed with the main intention of replacing a number of Regin's Aqualine controllers.

All configuration and normal handling is done using the display and the knob on the front.

Optigo is designed primarily for DIN-rail mounting but can also be screw-mounted to any suitable surface.

In- and Outputs

Optigo OP5 has:

- 1 analogue input, PT1000
- 1 analogue input for an external setpoint device, PT1000 (from R18)
- 1 universal input, 0...10 V DC or digital
- 1 digital input
- 2 analogue outputs, 0...10 V DC

Control modes

Optigo OP5 is pre-programmed with a choice of 5 different control modes:

- Temperature control
- CO₂ control
- Humidity control
- Pressure control
- Pressure control with outdoor-temperature dependent compensation

Chapter 3 Technical data

Supply voltage	24 V AC \pm 15%, 50...60 Hz
Power consumption	3 VA
Ambient temperature	0...50°C
Ambient humidity	Max 90% RH
Storage temperature	-20...70°C
Terminals	Disconnectable, so-called lift type for cable cross-section 2.5 mm ²
Protection class	IP20
Material casing	Polycarbonate, PC
Colour	
Cover	Silver
Bottom part	Dark gray
Weight	215 g incl. terminals
Dimensions	122 x 120 x 64 mm (WxHxD incl. terminals)

LVD, Low Voltage Directive

This product conforms with the requirements of European LVD standard IEC EN 61010-1.

EMC emissions an immunity standard

This product conforms with the requirements of European EMC standards CENELEC EN 61000-6-1 and EN 61000-6-3 and carries the CE mark

Inputs

AI	Resolution: 10 bit A/D
AI1	PT1000-sensor, range -30...+54°C, accuracy +/- 0.2°C
SPI	PT1000 setpoint device, range 0...40°C
A _{GND}	Reference for AI and for UI when used as an analogue input
UI	
AI	0...10 V DC, accuracy +/- 0.15 % of full output
or DI	Closing potential-free contact
UI+	Reference for UI when used as a digital input
DI	Closing potential-free contact
DI+	Reference for DI

Output

AO	0...10 V DC; 8 bit D/A short-circuit protected
----	--

Other data

Display	Numeric / graphic. Background illumination
---------	--

Settings

	Range	Factory setting
Setpoint CO ₂ Humidity (RH) Pressure (Pa) Temperature	0...100% of max set value on UI1 0...100% of max set value on UI1 0...100% of max set value on UI1 0...40°C	2000 ppm 100% RH 5000 Pa 21°C
10 V DC in on UI1 CO ₂ Humidity Pressure	0...9900 ppm 0...100% RH 0 Pa...500 kPa	2000 ppm 100% RH 5000 Pa
Neutral zone	10% of max	1% (control mode 1) 5% (control mode 3)
P-band CO ₂ Humidity (RH) Pressure (Pa)	0...100% of UI1 0...100% of UI1 0...300% of UI1	5% of UI1 5% of UI1 5% of UI1
I-time	0...990 s	10 s
Outdoor compensation start	-30...50°C	0°C
Pressure at -20°C outdoor temperature	0 Pa...500 kPa	1000 Pa

Accessories

External temperature sensors..... For example: TG-R5/PT1000, TG-KH/PT1000
 Setpoint device PT1000, e.g. TG-R4/PT1000 or TBI-PT1000
 CO₂-sensor CO2RT, CO2RT-D, CO2DT
 Humidity sensor HRT, HRT250, HDT3200, HDT2200
 Pressure sensor DMD, DTL-series, DTK-series, TTK-series

The accessories are available from Regin. For more detailed information, see product sheets and instructions which are available at www.regin.se.

Chapter 4 Installation and wiring

Installation

Optigo must be mounted in a DIN-standard casing (minimum 7 modules) or in a cabinet, either on a DIN-rail or, using the two screw-pockets provided, by being screwed to any suitable flat surface in the cabinet. The controller can also be mounted in a cabinet door or other control panel, using a suitable front-mounting kit.

Ambient temperature: 0...50°C.

Ambient humidity: max. 90 %RH, non-condensing.

Wiring

This section only describes general rules and technical limitations concerning the wiring. In chapter 5 there are specific wiring diagrams for the different control modes. Choose the one suitable for the application on hand.

It is important to make sure that the wiring is correctly done, in accordance with the instructions given in this manual and in accordance with local legislation for this type of installation.

1	G	24 V AC supply voltage
2	G0	
3	~	

20	AGND Ref. for AO1 and AO2
21	AO1 0...10 V DC Output
22	AO2 0...10 V DC Output

41	DI+ Reference for DI1
42	DI1 Digital input
43	UI+ Reference for UI1 digital mode
44	UI1 0...10 V DC or Digital input
50	AGND Ref. for AI1 and UI1 analogue
51	AI1 PT1000 temp. sensor input
52	SPI Input PT1000 setpoint device

Supply voltage

24 V AC $\pm 15\%$, 50...60 Hz. 3 VA

If the Optigo OP5 and active sensors and actuators connected to it share transformer, it is essential that the same transformer-pole is used as reference for all the equipment. Failure to do so will prevent the equipment from functioning as intended and may also lead to damages.

Inputs and outputs

A_{GND}

All A_{GND} terminals are interconnected and also connected to G0.

Analogue input AI

The analogue inputs must refer to an A_{GND} terminal. AI1 is for PT1000 temperature sensors only. Temperature range: -30...+54°C. SPI is only intended for a PT1000 setpoint device, the range is 0...40°C.

Note: For temperatures below -9.9°C decimals will not be displayed. So make sure to differ between for example -2.7 (minus two point seven) and -27 (minus twentyseven).

Digital input DI

The digital input must refer to DI+ on terminal 41.

The digital input may only be wired to voltage-free contacts. Any external voltage applied to a digital input may seriously damage the unit.

Universal input UI

The universal input can, depending on the choice of application, be made to act as either an analogue input or as a digital input.

When used as an analogue input it is for 0...10 V DC input signals.

When the Universal input is used as an analogue input it must refer to the A_{GND} terminal or directly to G0.

When used as a digital input it must refer to UI+ on terminal 43. It may then only be wired to voltage-free contacts.

Analogue outputs

Analogue outputs must refer to a A_{GND} terminal or directly to G0.

If the Optigo OP5 and active sensors and actuators connected to it share transformer, it is essential that the same transformer-pole is used as reference for all the equipment. Failure to do so will prevent the equipment from functioning as intended and may also lead to damages.

Chapter 5 Control modes

Optigo can be configured to any one of the following control modes.

1. Temperature control.

The temperature at the sensor is kept at the setpoint value by controlling the output signals on AO1 and AO2. A single PI control loop is used.

2. CO₂ control.

The CO₂-value at the sensor is kept at the setpoint value by controlling the output signal on AO1. A single PI control loop is used.

3. Humidity control.

The humidity at the sensor is kept at the setpoint value by controlling the output signals on AO1 and AO2. AO1 is used for humidification, AO2 for dehumidification. A single PI control loop is used.

4. Pressure control.

The pressure at the sensor is kept at the setpoint value by controlling the output signal on AO1. A single PI control loop is used.

5. Pressure control with outdoor compensation.

The pressure at the sensor is kept at the setpoint value by controlling the output signal on AO1. The setpoint is automatically adjusted according to the outdoor temperature. A single PI control loop is used.

Control mode 1, Temperature control

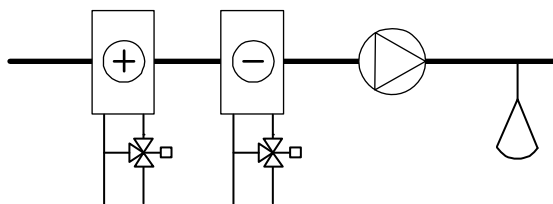

The analogue outputs can be configured to the following combinations:

AO1 / AO2

1. Heating / -
2. Cooling / -
3. Heating / Cooling
4. Heating / Heating
5. Cooling / Cooling
6. Heating / Damper
7. Cooling / Damper
8. Change-over/ - (Seasonal change-over between heating and cooling)

In alternative 4, Heating-Heating AO2 will be activated first on increasing heat demand.

In alternative 5, Cooling-Cooling AO2 will be activated first on increasing cooling demand.

In alternative 6, Heating-Damper, at temperatures above the setpoint the damper on AO2 will be fully open. On increasing heating demand, the damper on AO2 will first close to the set minimum value before the heating output on AO1 starts to increase.

In alternative 7, Cooling-Damper, at temperatures below the setpoint the damper on AO2 will be fully open. On increasing cooling demand, the damper on AO2 will first close to the set minimum value before the cooling output on AO1 starts to increase.

DI1, Start signal

Normal control will only be activated when this input is activated, closed. Active signal is indicated by a fan-symbol in the display. When the start signal is deactivated the controller will set the outputs to 0.

Note: This input must always be wired since it controls the starting and stopping of normal control.

Universal input UI1, Change-over

The change-over function will make a seasonal change of the function of the output signal on AO1. In summer the output will work as a cooling output and in winter as a heating output. This is used in applications (fan-coil units) where the same piping is used to transport hot water in the winter and chilled water in the summer.

The universal input UI1 is used for the change-over function in alternative 8. Wire the input as a digital input using either a manual switch or a thermostat monitoring the supply water temperature to open/close the input. Open contact will give heating control and closed contact cooling control.

Damper

In applications with dampers it is often desirable to be able to set a minimum amount of fresh air. In the output alternatives 6 and 7 it is possible to set a minimum limit value to the damper output signal. The damper output will then not go lower than the set value during normal operation. When DI1=0, however, the signal will go to zero.

In the output mode heating – damper the damper will be fully open for temperatures higher than the setpoint. On increasing heat demand the damper will first close to the minimum value before the heating output starts to increase.

In the output mode cooling – damper the damper will be fully open for temperatures lower than the setpoint. On increasing cooling demand the damper will first close to the minimum value before the cooling output starts to increase.

External setpoint

From revision 18, it is possible to use an external PT1000 setpoint device, e.g. TG-R4/PT1000 or TBI-PT1000. The setpoint device is connected between terminal 52 SPI and the reference for the analogue inputs, AGND. For more information on configuration and setpoint reading, see chapters 7 and 8.

Wiring example: Heating / cooling with change-over function

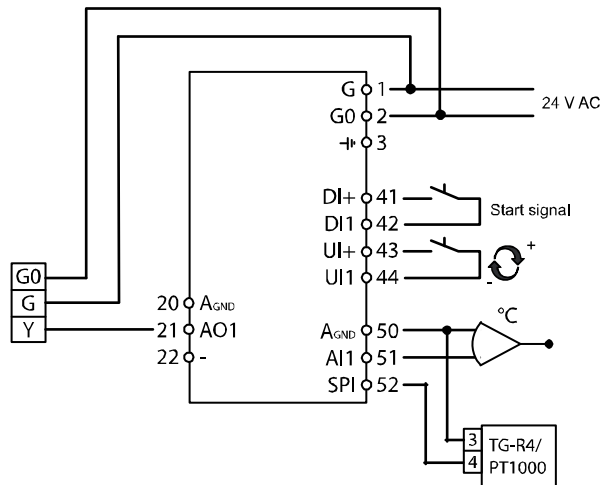

Control mode 2, CO₂ control

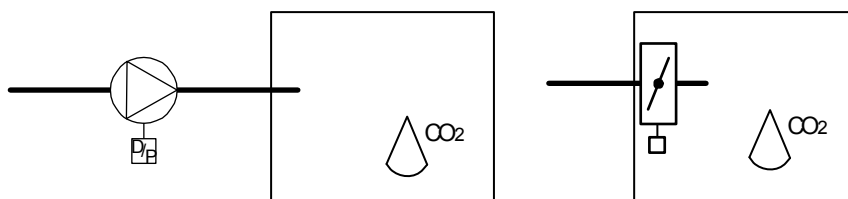

The output signal will increase when the CO₂-value rises above the setpoint value.

The CO₂-sensor must have a 0...10 V DC output for example:

CO2RT, CO2RT-D Room sensors

CO2DT Duct sensor

The transmitter range cannot exceed 9900 ppm at 10 V DC output.

DI1, Start signal

Normal control will only be activated when this input is activated, closed. When the start signal is deactivated the controller will set the output to 0.

Note: This input must always be wired since it controls the starting and stopping of normal control.

Wiring example: CO₂-control using damper or frequency converter

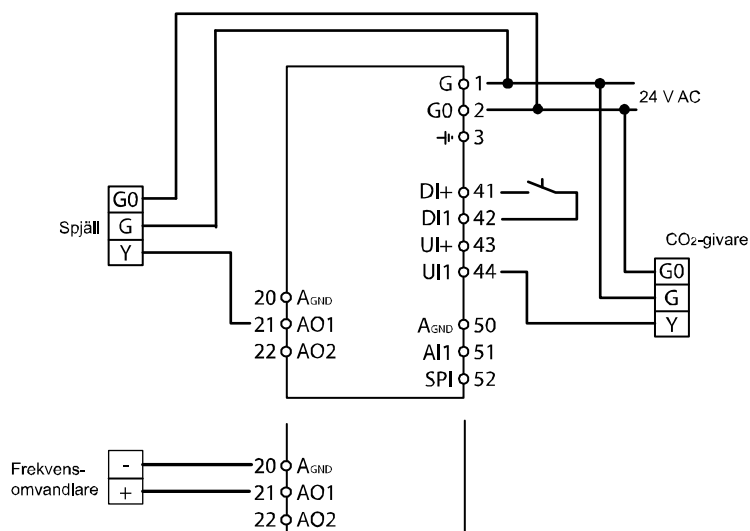

Control mode 3, Humidity control

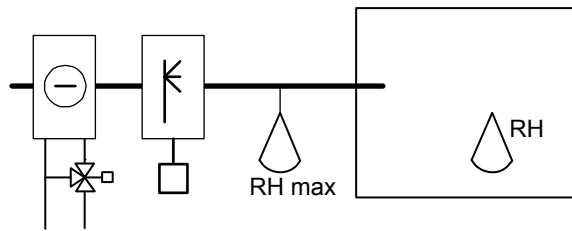

Humidification and dehumidification can be used simultaneously. A neutral zone can be set between humidification and dehumidification.

The humidity transmitter must have an output signal of 0...10 V DC, for example:

HRT, HRT250 or HRT350	Room humidity transmitters
HDT2200 or HDT3200	Duct transmitters

DI1, Start signal

Normal control will only be activated when this input is activated, closed. When the start signal is deactivated the controller will set the outputs to 0.

Maximum Limiting, RH Max

When running humidification with the main sensor in the room it is sometimes desirable to have some sort of maximum limiting on the humidity in the supply duct.

To create such a limiting function, place an on/off humidistat such as HMH in the supply air duct and wire it into the start signal circuit on DI1. The humidistat should be normally closed.

Opening of the contact when the humidity rises above the set maximum value will force the humidity output to 0.

Wiring example: Combined humidification / dehumidification

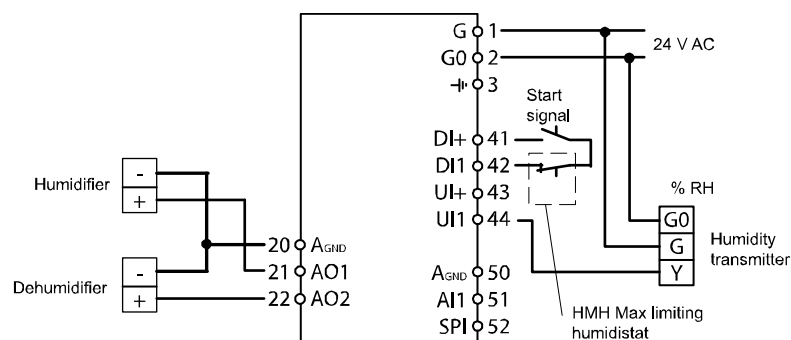

Control mode 4, Pressure control

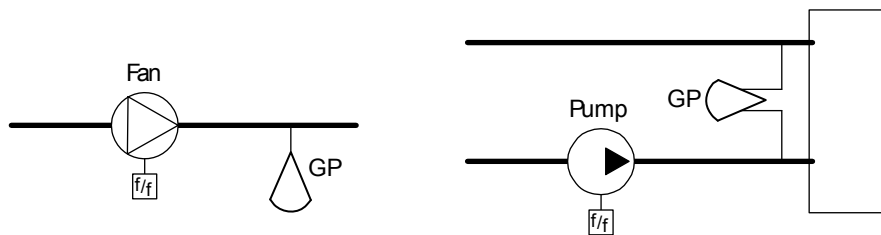

The output signal will increase when the pressure signal falls below the setpoint value.

The pressure transmitter must have an output signal of 0...10 V DC, for example:

DMD

DTL-series

DTK-series

TTK-series

Pressure ranges up to 500 kPa can be set.

DI1, Start signal

Normal control will only be activated when this input is activated, closed. When the start signal is deactivated the controller will set the output to 0.

Note: This input must always be wired since it controls the starting and stopping of normal control.

Wiring example. Pressure control

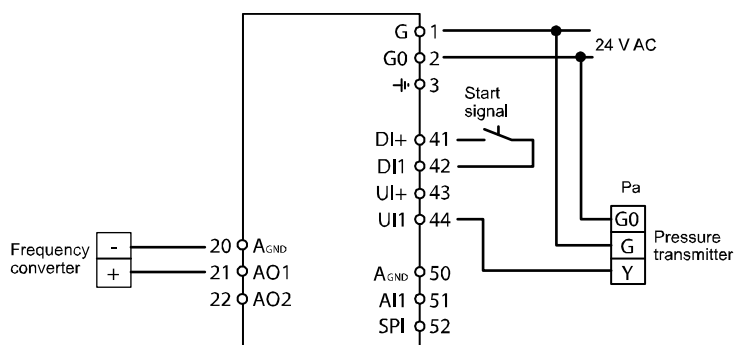

Control mode 5, Pressure control with outdoor temperature compensation of the pressure setpoint.

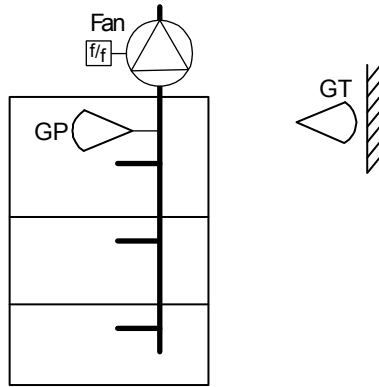

The output signal will increase when the pressure signal falls below the setpoint value.

The setpoint value follows a settable pressure-to-outdoor temperature relation.

The pressure transmitter must have an output signal of 0...10 V DC, for example:

DMD

DTL-series

DTK-series

TTK-series

Pressure ranges up to 500 kPa can be set.

DI1, Start signal

Normal control will only be activated when this input is activated, closed. When the start signal is deactivated the controller will set the output to 0.

Note: This input must always be wired since it controls the starting and stopping of normal control.

Wiring example: Outdoor temperature compensated pressure control

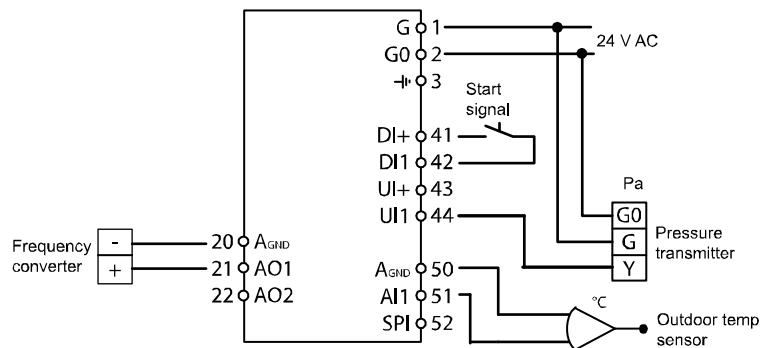

Chapter 6 Display and encoder

All setting and configuration is done using the display and encoder.

The menu information on the display is organised in a tree fashion. Using the encoder you can move between menus, set values etc.

In any of the configuration menus, a click on the encoder will activate change mode. You can then rotate the encoder button to move between choices or set values. A second click of the button will accept the choice.

The menu system is divided into two levels: The Basic level and the 10-second level which contains all the configuration menus.

The Basic level

The Basic level comprises three sets of menu displays, the Base Display, the I/O Displays and the Setpoint Display.

Base Display

This is an example of the Base Display, the display that is normally shown when there is no operator activity.



The upper line shows which control mode has been configured, in this case control mode 1, Temperature control. The bottom line shows the actual value of the main input parameter. There are bar-graphs showing the current output levels. In control mode 1 there are symbols showing how the outputs have been configured (Heating, Cooling, Damper or Change-over).

I/O

When the Base Display is shown, by twisting the knob counter clockwise until the text I/O is displayed and then clicking on it, you can gain access to a menu where you can look at the values and states of all inputs and outputs.

To exit this menu again, click on the knob and then twist the knob clockwise and you will be returned to the Base display.

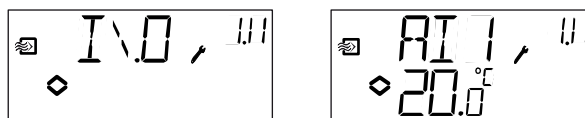

Setpoint

When in the Base Display, a click on the encoder button gives direct access to the Setpoint menu.

See chapter 7 Setpoint.



Calculated setpoint

In control mode 4, Pressure control with outdoor compensation, the controller does not work towards a fixed setpoint value. Instead, it works towards a calculated setpoint, which varies with the outdoor temperature. The calculated setpoint is displayed by turning the knob clockwise when in the Base Display.



The 10-second level

This level is reached from the Base Display by pressing and holding the encoder button for 10 seconds. The 10-second level holds all the configuration menus. See chapter 8 Configuration.

Note: The controller must display the Base Display when pressing the encoder knob to reach the 10-second level.



Display symbols

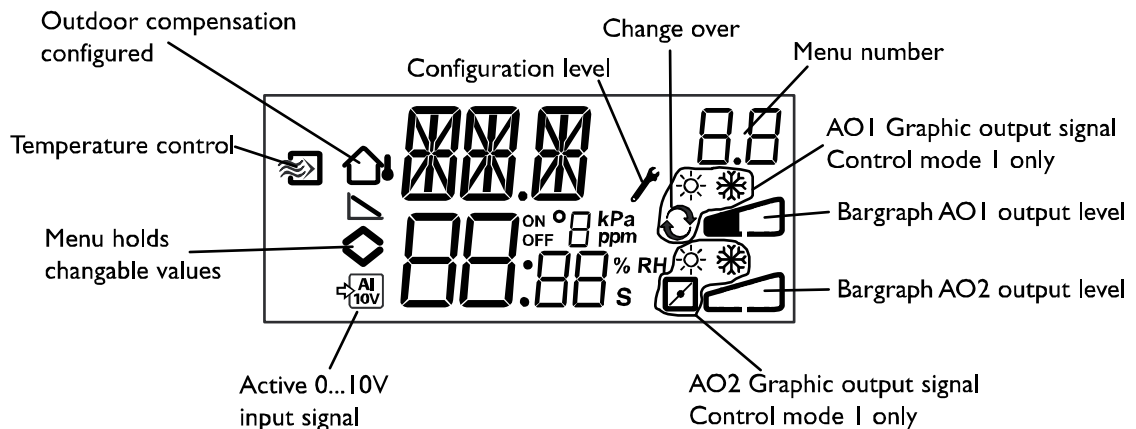

Chapter 7 Setpoint

The setpoint menu is normally accessed from the Base Display by a clicking on the encoder knob.

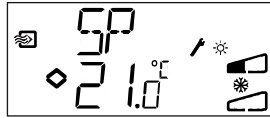

If you wish to change the displayed value, click on the knob again and the change indicators will start to flash to show that you are now in change mode. Twist the knob, clockwise to increase the value, counter-clockwise to decrease.

In applications with active input signals (control modes 2, 3, 4 and 5) the setpoint cannot be set higher than the value corresponding to 10 V DC input signal.

When the desired value is shown, click on the knob to acknowledge. To return to the Base display, twist the knob.

For configurations involving a single output signal the setpoint is the starting point for the output signal.

For configurations involving two diverging output signals with neutral zone (heating – cooling or humidification – dehumidification) the setpoint is placed in the middle of the neutral zone.

For configurations involving two outputs without neutral zone (heating – heating, cooling – cooling, heating – damper or cooling – damper) the setpoint value is the starting point for the first sequence (Y2)

External setpoint (SPI)

When using an external setpoint device, the setpoint can be read by clicking on the knob while in the base display. If you click on the knob again, a symbol will start to blink, indicating that an external setpoint device is being used and that the setpoint cannot be changed via the display. External setpoint can be used for control mode 1. The SPI input can also be read via the I/O menu.

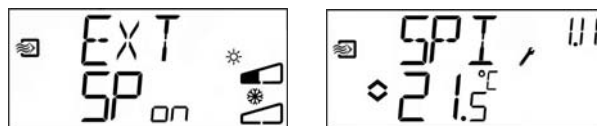

Chapter 8 Configuration

All the configuration menus lie in the 10-seconds level. This level is accessed from the Base Display by pressing and holding the encoder button for 10 seconds.

There are numerous configuration menus covering all available options and combinations. In some cases, making a certain choice in one menu will mean that you will only see certain other menus. For example, the menu for setting the damper minimum limit is only shown if you have configured AO2 to be a damper control output.

Menus 1.0 – 5.0

In the first set of configuration menus you choose which of the five control modes you wish to run. The upper text row, the lower text row number and the first digit in the menu-number show which control mode is at hand.

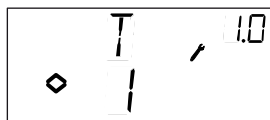

1. Temperature control



2. CO2-control

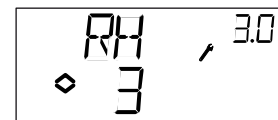

3. Humidity control

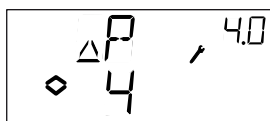

4. Pressure control

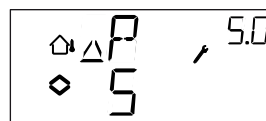

5. Pressure control with outdoor compensation

Menu X.1

Output signals (Control mode 1)

Transmitter range (Control modes 2, 3, 4 and 5)

Control mode 1.

For temperature control there is a choice of 8 different output signal combinations. Select one fitting the application on hand.

AO1	/	AO2	Output symbol	Graphic symbol
1. Heating	/	-	\	☀
2. Cooling	/	-	/	❄
3. Heating	/	Cooling	\/	☀ ❄
4. Heating	/	Heating	\\	☀ ☀
5. Cooling	/	Cooling	//	❄ ❄
6. Heating	/	Damper	\/	☀ ☑
7. Cooling	/	Damper	\/	❄ ☑
8. Change-over	/	-		↻

In alternative 4, Heating-Heating AO2 will be activated first on increasing heat demand.

In alternative 5, Cooling-Cooling AO2 will be activated first on increasing cooling demand.

In alternative 6, Heating-Damper, at temperatures above the setpoint the damper on AO2 will be fully open. On increasing heating demand, the damper on AO2 will first close to the set minimum value before the heating output on AO1 starts to increase.

In alternative 7, Cooling-Damper, at temperatures below the setpoint the damper on AO2 will be fully open. On increasing cooling demand, the damper on AO2 will first close to the set minimum value before the cooling output on AO1 starts to increase.

For each alternative the number representing it is shown along with a graphic symbolisation of the output signals and also a symbol next to the bar-graph for each output.

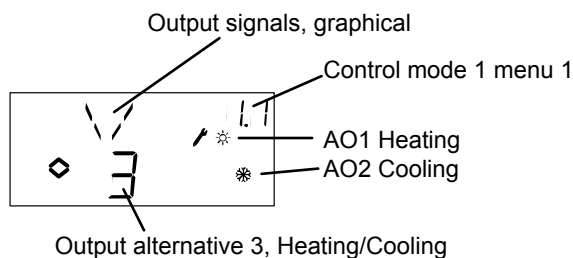

Example, Menu 1.1
Temperature control with output alternative 3 Heating/Cooling

Control modes 2, 3 4 and 5

For control modes using active 0...10 V DC transmitters you need to scale the input signal. For example, if you have a pressure transmitter that will give a 0...10 V output for a pressure range of 0 to 5000 Pa, set the value to 5000 Pa. Note that for pressure transmitters the pressure, depending on the range, may be given in Pa or kPa. Ranges up to 500 kPa can be set. Also, not all values between 0 and 500 kPa can be set since this would involve a great amount of twisting on the encoder. In the low ranges the values are close but become increasingly further between as the values go up.

For CO₂ transmitters the range is set in ppm and for humidity control in % RH.



Example, Menu 2.1
CO₂-control with input signal 0...10 V for CO₂ value 0...2000 ppm.

Menus X.2

Neutral zone (Control mode 1 and 3)

In two control modes involving diverging output signals (heating – cooling or humidification – dehumidification) you can set a neutral zone between the outputs. The setpoint will be placed at the middle of the neutral zone.

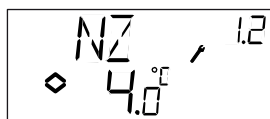

Menus X.3 P-band

Here you set the P-band (Proportional band) The P-band unit depends on the choice of control mode. The P-band is the control offset necessary to drive an output signal from 0 to 100%. In configurations involving two outputs the same P-band applies to both outputs.



Menus X.4 I-time

Here you set the Integration time (Reset time). If the I-time is set to 0 the integration function is disabled and the controller will act as a P-controller.

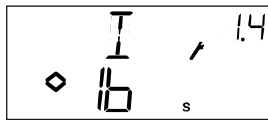

Menu 1.5 Damper minimum position (Control mode 1 only)

If you in menu 1.1 have configured output AO2 to be a damper, alternative 6 or 7, you can set a minimum value to the damper signal. . The damper output will then not go lower than the set value during normal operation. On shut-down however the signal will go to zero and fully close the damper.



Menu 5.9 Start point for outdoor compensation (Control mode 5 only)

S.P is the outdoor temperature at which the setpoint compensation starts. At temperatures higher than S.P the normal setpoint value is maintained. When the outdoor temperature falls below S.P the pressure setpoint will change linearly on decreasing temperature to reach the pressure set by SPL in menu 5.8 below at an outdoor temperature of -20°C



Menu 5.9

Maximum compensation (Control mode 5 only)

SPL is the setpoint to be held at an outdoor temperature of -20°C . The setpoint shift starts when the outdoor temperature falls below the value set in S.P in menu 5.7 above and will change linearly with decreasing outdoor temperature reaching SPL when the outdoor temperature is -20°C . Note that SPL is not a setpoint shift value to be added to the normal setpoint value but the actual setpoint value at -20°C outdoor temperature.

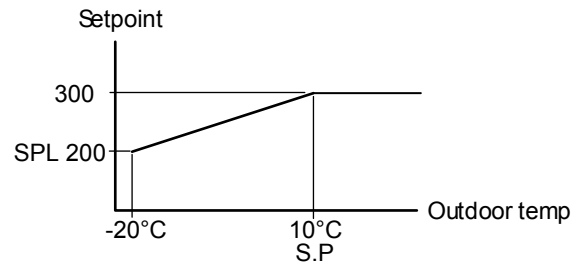

Example: With an ordinary setpoint of 300 Pa, a starting point S.P of $+10^{\circ}\text{C}$ and a SPL of 200 Pa at -20°C you get the following setpoint-to-outdoor temperature relation

Menu 1.E

External setpoint (control mode 1)

In this meny, you set whether you want to use an external setpoint device or set the setpoint via the display. External setpoint can be used for control mode 1. This menu is only available for controllers with revision number R18 or later.



Menus X.11 I/O

After the last configuration menu there is a menu where you can look at the actual values of all the inputs and outputs. This menu can also be accessed directly from the Base Display by twisting the encoder knob counter clockwise and then pressing. See chapter 6.

Menu OK

Last of the configuration level menus is the OK-menu. To leave the configuration level, go to this menu and press the encoder knob.



On exit from the configuration level you will be returned to the Basic level.

There is also a time-out function that will automatically exit the configuration level after 5 minutes of inaction.

Storage of settings

All configuration settings become valid as soon as they are entered by clicking the encoder knob. They are however not written to the flash memory until you exit the configuration level either via the OK menu or via the time-out function.

To exit the configuration level without saving the changes to flash memory, cut the supply voltage when still in the configuration level. All values will be kept as they were before you entered the configuration level.

Reset to factory setting

The OP5 can be reset to factory settings by configuring Humidity control (mode 3) and setting the transmitter range to 100% and the P-band to 99. Then cut the power supply. When power is reapplied all configuration settings will be reset to factory setting.

Chapter 9 Index

1	
10 second level	20
A	
Analogue inputs	11
Analogue outputs	11
B	
Basic level	19
C	
Change-over	13
Configuration	22
Configuration level	20
Control modes	7, 12
1, Temperature control	13
2, CO ₂ control	15
3, Humidity control	16
4, Pressure control	17
5, Pressure control with outdoor temperature compensation of the pressure setpoint	18
D	
Damper limiting	14, 24
Digital inputs	11
Display and encoder	19
E	
EMC	8
F	
Factory settings, reset to	26
H	
Humidity control Maximum limiting	16
I	
Inputs and outputs	7, 11
Analogue inputs	11
Analogue outputs	11
Digital inputs	11
Universal inputs	11
Installation	10
I-time	24
L	
LVD	8
M	
Menu	
Configuration	22
I/E	25
I/O	19, 25
OK	25
Setpoint	19, 21
Mounting	6
R	
Reset time	See I-time
S	
Setpoint	21
Start signal	13, 15, 16, 17, 18
Supply voltage	10
T	
Technical data	8
Inputs	8
Outputs	8
U	
Universal inputs	11
V,W	
Wiring	10
Wiring diagram	
Control mode 1	14
Control mode 2	15
Control mode 3	16
Control mode 4	17
Control mode 5	18
general	10



AB Regin

Head office

Box 116, S-428 22 Källered,
Sweden

Phone: +46 31 720 02 00
Fax: +46 31 720 02 50

info@regin.se
www.regin.se

Germany

RICCIUS + SOHN GmbH

Haynauer Str. 49
D-12249 Berlin

Phone: +49 30 77 99 40
info@riccius-sohn.eu
www.riccius-sohn.eu

France

Regin Controls SARL

32 rue Delizy
F-93500 Pantin

Phone: +33 1 41 71 00 34
info@regin.fr
www.regin.fr

Spain

Regin Ibérica, S.A.

C/Arganda 18 local
E-28005 Madrid

Phone: +34 91 473 27 65
info@regin.es
www.reginiberica.com

Singapore

Regin Controls
Asia Pacific Pte Ltd

66 Tannery Lane
03-04 Sindo Building
Singapore 347805

Phone: +65 6747 8233
info@regin.com.sg
www.regin.com.sg

Hong Kong

Regin Controls
Hong Kong Ltd

Room 2901
EW International Tower
120 Texaco Road
Tsuen Wan, NT
Hong Kong

Phone: +852 2407 0281
info@regin.com.hk
www.regin.com.hk